

Cuffed Draperies on Arch

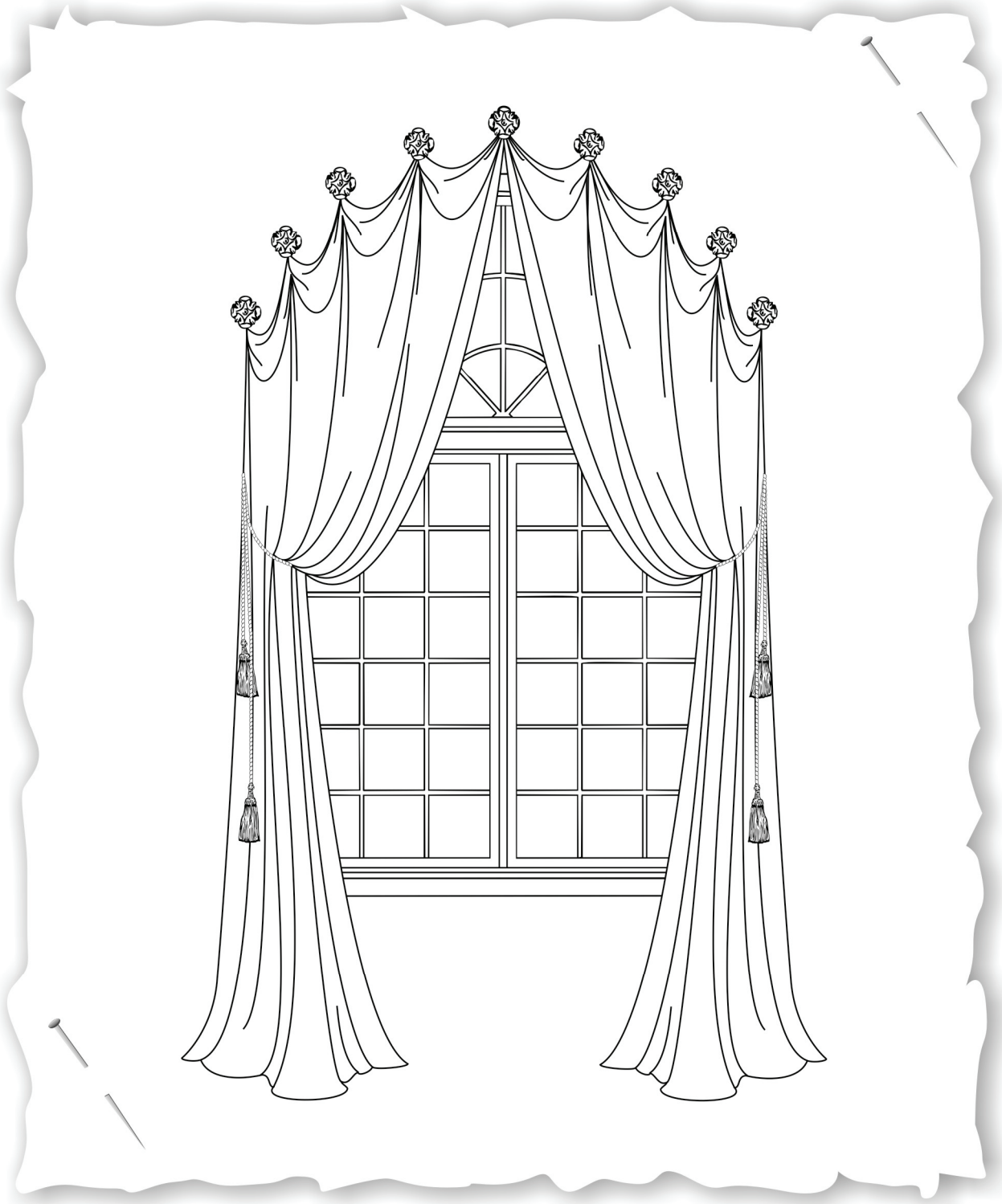

Cuffed Draperies on Arch

- ✓ Draperies will be installed on some type holdback. Holdbacks are spaced 10" - 15" apart.
- ✓ FL of cuffs can vary from 3" - 5". This instruction has a 3" finished cuff.
- ✓ This instruction is for an 80" W x 100" L window; drapery is an outside mount.

1.	<p>Yardage: * Figures Based on 80" W *</p> <table border="1"> <thead> <tr> <th>Size</th> <th>Solid Fabric Yds</th> <th>27" Repeat Yds</th> <th>Cuff Yds</th> </tr> </thead> <tbody> <tr> <td>Up to 96" FL</td> <td>9.50</td> <td>11.25</td> <td>4.00</td> </tr> <tr> <td>97" to 108" FL</td> <td>10.50</td> <td>11.25</td> <td>4.00</td> </tr> <tr> <td>109" to 120" FL</td> <td>11.50</td> <td>13.50</td> <td>4.00</td> </tr> </tbody> </table>	Size	Solid Fabric Yds	27" Repeat Yds	Cuff Yds	Up to 96" FL	9.50	11.25	4.00	97" to 108" FL	10.50	11.25	4.00	109" to 120" FL	11.50	13.50	4.00
Size	Solid Fabric Yds	27" Repeat Yds	Cuff Yds														
Up to 96" FL	9.50	11.25	4.00														
97" to 108" FL	10.50	11.25	4.00														
109" to 120" FL	11.50	13.50	4.00														
2.	<p>Face fabric cuts:</p> <p>Width: FW x 1³/₄ to 2 = _____</p> <p><i>Formula: FW, multiplied by 1³/₄ to 2 for fullness.</i></p> <p>1. Three widths of 54" fabric are needed for an 80" window.</p> <p>Length: FL + 16" + 2" to 4" (see formula) = _____</p> <p><i>Formula: FL (top of arch to floor, see tips below), plus 16" (hem), plus 2" to 4" (break/puddle on floor or preference).</i></p> <p>1. To determine FL, use Sausage Bead Weight at client's house.</p> <ol style="list-style-type: none"> a. Start at center mounting mark > pull back for desired look. b. Mark Sausage Bead Weight at floor, this represents lead edge FL. c. Be sure to note height of tieback placement. (see dia. 1) <p>2. Since hemline is cut on an angle, a deduction of 3" can be made from lead edge to allow for adjustments when installing. Only lead edge is cut longer to allow for drapery being tied back.</p> <ol style="list-style-type: none"> a. Most lead edges pull up some as they are tied back. b. The illustrations in this instruction reflect the 3" deduction. 																
3.	<p>Cuff fabric cuts:</p> <ol style="list-style-type: none"> 1. Cuff can be a contrasting fabric. 2. Cuff: See step 7.15. 3. Facing: See step 7.18. 4. Piping: (optional): Piping can be added along bottom of cuff. 																
4.	<p>Lining cuts:</p> <p>Width: Same as face fabric cuts.</p> <p>Length: Face fabric cut length - 16" + 2" = _____</p> <p><i>Formula: Face fabric cut length, minus 16" (hem difference), plus 2" (trim allowance).</i></p>																
5.	<p>Interlining cuts:</p> <p>It is best to cut interlining & let it rest 24 hours before fabricating. (see Quick Tips - Interlining)</p> <p>Drapery Width: Same as face fabric cuts.</p> <p>Drapery Length: Face fabric cut length - 16" - 7¹/₂" + 2" = _____</p> <p><i>Formula: Face fabric cut length, minus 16" (hem), minus 7¹/₂" (hem difference), plus 2" (trim allowance).</i></p> <p>Cuff: Cut same as face fabric.</p> <ol style="list-style-type: none"> 1. When using lightweight fabric interlining may be necessary. 																

6. **Mock up board:**

1. Cut a piece of plywood slightly larger than half of desired FW & long enough to accommodate all holdbacks.
2. Draw half of arch on plywood to represent casing of window. (see dia. 2)
3. Cut a 1x 4 board & attach at top on back of plywood to serve as dust cover to mount board.
4. Determine number of holdbacks to be used.
 - a. Spacing should be 10" - 15" apart & **4" above window casing**. Center mark is displayed 1" down from top of board. (see dia. 2)
 - b. The spacing for this example is 12½". (see dia. 2)
5. Mark holdback placement on plywood > insert screws or holdback posts. (see dia. 2)
6. **Tip:** To ensure that spaces cup, placement of last holdback will be 10" - 15" above bottom of window arch. (First mark on dia. 2 is 13" from bottom of window arch; measurement starts from top of board.)
7. Place mock up board on Z brackets & screw to dust cover to secure. (bracket for ceiling mounts available from Rowley Company)

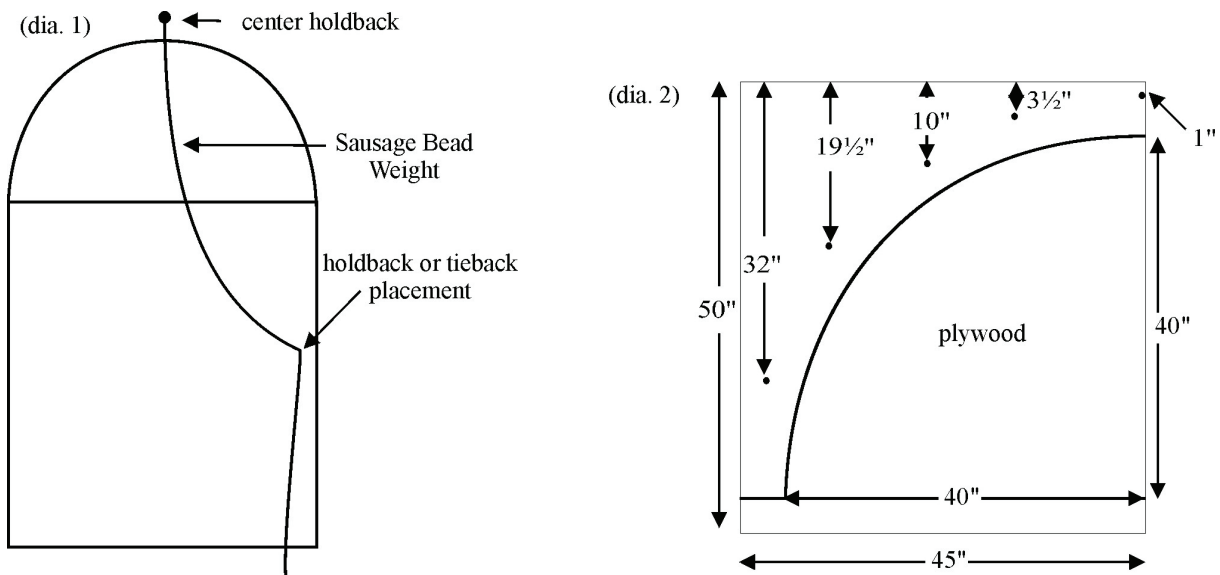

7. **Fabrication:**

1. Sew whole & half panel together, if applicable.
2. **Mark 3" for side hems** on each side of panels.
3. Divide **remaining fabric** by number of desired spaces.
 - a. This example has four spaces.
4. Mark spacing with disappearing pen. (disappearing pens available from Rowley Company – see Sources/Sewing Supplies)
 - a. Draw a 15" vertical line down from each mark.
 - b. Check to make sure lines will not be permanent on face fabric.
5. With push pins, place top of fabric at top of mock up board.
 - a. Lines should be spaced to line up with holdbacks.
6. Mark actual holdback location. (see dia. 2)
7. Remove fabric from mock up board & place right side up on table.
8. To create arch, draw a line to connect marks, cut off excess, leave a ½" seam allowance. (see dia. 3)
 - a. **IMPORTANT:** Make a permanent mark **in seam allowance** at each holdback location.
9. Return panel to mock up board to check cupping.
10. Using measurement from Sausage Bead Weight; mark FL of **lead edge plus 16" (hem)**.
11. On wrong side of face fabric, draw a diagonal line from lead edge to return edge to represent diagonal cut line along bottom of drapery.
 - a. Measurement for return edge is top of center holdback to floor, plus 16" (hem), plus break/puddle allowance.
 - b. **Bottom hem of interlining & lining will be same angle.**

Fabrication (continued):

12. Fold a doubled 8" bottom hem in face fabric > blindstitch > trim off excess on lead edge.
13. Fold a doubled 3" bottom hem in lining > blindstitch > trim off excess on lead edge.
14. Serge across bottom of interlining to finish raw edge.
15. **For Cuff:**
 - a. Place another piece of face fabric under drapery panel, face side up. Both pieces should be face side up.
 - b. Draw a line to duplicate curve of panel. (see dia. 4)
 - c. Remove drapery panel.
16. **For Cuff Lining:**
 - a. Place another piece of face fabric under cuff fabric, **wrong sides together**. (see dia. 4)
 - b. Following the curve line, draw a second line 4" - 5" down & cut along lines.
 - c. When using interlining, cut same as cuff.
17. **Important:** Cut all layers at one time.
18. **Facing:**
 - a. Repeat step 7.16.
 - b. Facing will be **1" longer than cuff**.
19. Stitch covered piping along bottom edge of cuff.
 - a. Interlining should be on back of cuff.
20. With right sides together stitch cuff & cuff lining along bottom edge. (see dia. 5)
21. Finish cuff 6" shorter than drapery panel to allow for side hems.
22. **Tip:** On return side, cuff should be finished at an angle.
 - a. Trimming cuff return edge allows cuff & panel edges to align. (see dia. 5 & 7)
23. Turn & press cuff.

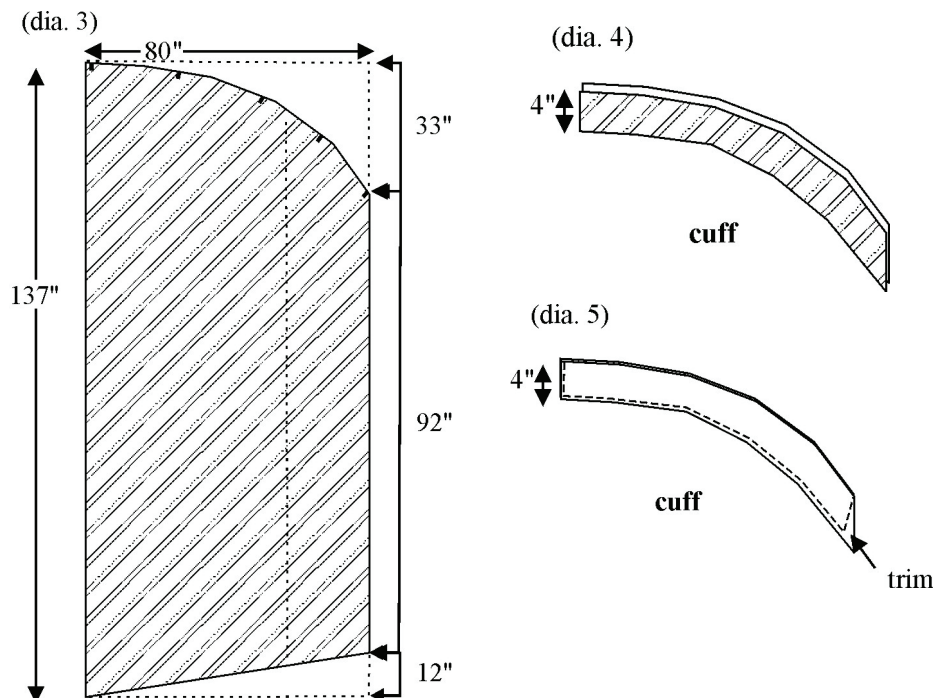

Fabrication (continued):

24. Place drapery lining on table wrong side up.
25. Place drapery interlining 1" up from bottom of lining.
26. Place drapery (*face fabric*) face side up on top of interlining.
 - a. Face fabric should be 6½" longer than lining length. (*see dia. 6*)
27. Trim lining & interlining excess along top curve to match face fabric.
28. Place finished cuff right side up on drapery panel & 3" in from each side.
29. Stitch all layers along top curve line.
 - a. Glue baste to secure layers.
 - b. **Important:** Be careful not to stretch bias on curve.
30. Place panel that has been stitched along curve at top on table lining side up.
31. Fold > press doubled 1½" side hems. (*see dia. 6*)
32. Trim both sides of lining & interlining to FW of drapery.
 - a. For a thicker looking side hem, fold interlining into side hem & only trim 1½" off each side instead of 3".
33. Insert covered drapery weights in bottom of side hems. (*see How To's – Inserting drapery weights*)
34. Hand stitch or blindstitch side hems.
35. **Loops for holdbacks:**
 - a. Cut lengths of ribbon long enough to accommodate holdback posts.
 - b. Place loops at previous holdback markings > stitch. (*see dia. 6 & 7*)
36. Place facing wrong side up on top of cuff > stitch along stitch line.
37. Turn under approx. ½" along bottom & sides of facing & press.
38. Flip facing toward back onto lining > hand sew | use Iron-on Bonding tape to secure. (*see dia. 6*)

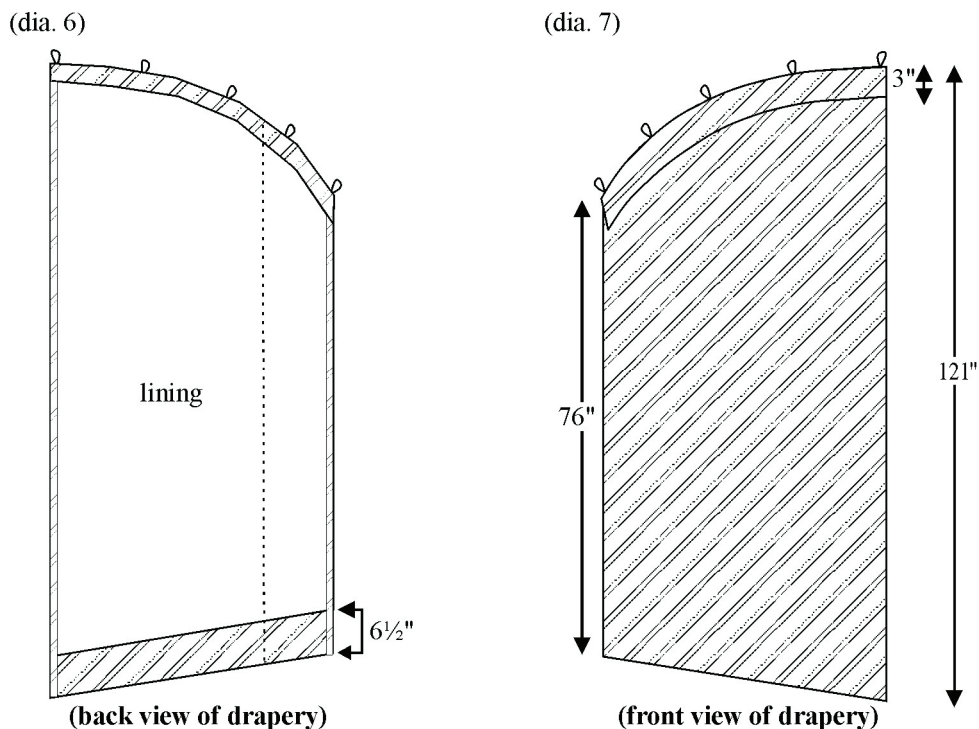

8. **Installation tips:**

1. Do not fanfold this drapery. Drapery should have soft folds when installed.
2. Install holdback posts according desired placement. (*see dia. 2*)
3. Place loops over posts & attach holdback.
4. Dress drapery panel with tieback or holdback according to previously determined measurement.